

Rotary Arm Series Stretch Wrappers

COBRA[®]

525 Semiautomatic



NEW!

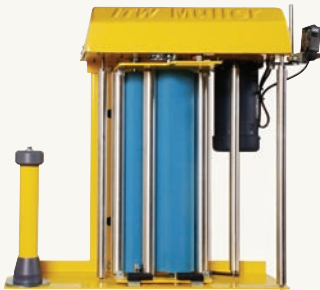

Octo-Thread

*Simplified film
threading with
improved operator
ergonomics*

- Wraps up to 35 loads per hour
- No weight limits—loads are wrapped on the floor
- Freestanding or column mounted designs
- Heavy duty construction
- Pre-stretches film up to 300%
- Positive, non-slip V-belt rotation drive
- PLC control
- Octo-Thread carriage allows easy film threading
- Strain gauge film delivery control

ITW Muller

Cobra 525

Semiautomatic Rotary Arm Stretch Wrapper

Specifications

Standard configuration listed below. Please contact your sales representative for other available configurations.

Performance

Loads per hour	Up to 35
Rotation speed	12 rpm
Maximum load size	50" x 50" x 80" H
Maximum load weight	Floor capacity

Film Delivery System

Film capacity	20" roll width x 10" dia.
Film payout	Strain gauge
Pre-stretch level	250% (optional 100% to 300%)
Force control	Variable
Film threading	Easy thread design
Carriage speed	Adjustable down speed

Controls

Controller	PLC
Operator Interface	Push button controls
Load height sensor	Photo eye
Wrap pattern	Fixed top and bottom wrap count. Select 2 & 2, 3 & 3, 4 & 4, 5 & 5. Reinforce wrap feature.
Emergency stop	Mushroom head
Electrical disconnect	Lockable
Electrical enclosure	CSA approved

Power Requirements

Voltage	120 VAC, 15 amp, 1 phase, 60 Hz
---------	---------------------------------

Rotary Arm

Drive system	Dual V-belt drive
Bearing type	Dual pillow block bearings

Structure

Installation	Column mounted or floor mounted
Machine weight	Column mounted: 1,400 pounds Floor mounted: 2,100 pounds
Construction	Heavy duty, welded
Frame color	Dark bronze
Rotating arm color	Yellow

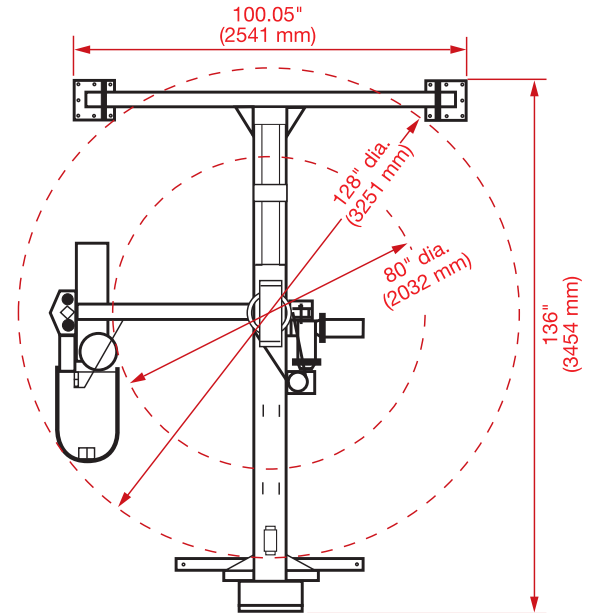

Dimensions shown are for the floor mounted model (gantry frame).

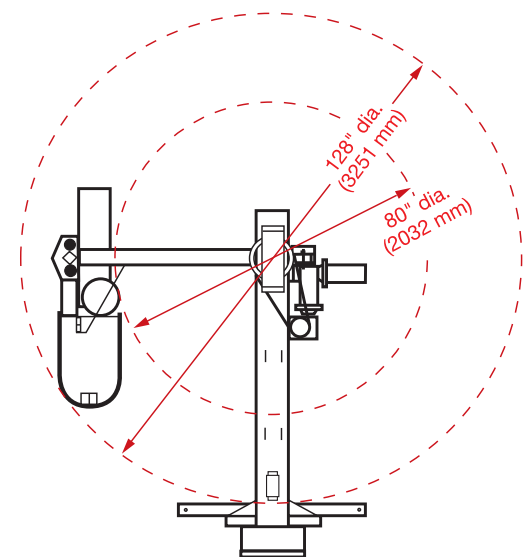

Dimensions shown are for the column mounted model.