

Turntable Series Stretch Wrappers

RAPTOR[®]

1525P Automatic

NEW!



*Simplified film
threading with
improved operator
ergonomics*

Octo-Thread



- Wraps up to 45 loads per hour
- 4,000 pound capacity
- Lift truck portable from front and rear
- Heavy duty construction
- Pre-stretches film up to 300%
- Ring and pinion drive
- Allen-Bradley PLC with operator interface
- Octo-Thread carriage allows ease of film threading
- Strain gauge film delivery control
- Remote start by pendant

ITW Muller

Raptor 1525P

Automatic Turntable Stretch Wrapper

Specifications

Standard configuration listed below. Please contact your sales representative for other available configurations.

Performance

Loads per hour	Up to 45
Rotation speed	Adjustable up to 16 rpm
Maximum load size	50" x 54" x 80" H (72" dia.)
Minimum load size	36" x 36" x 28" H
Maximum load weight	4,000 pounds
Turntable elevation	16"

Film Delivery System

Film capacity	20" roll width x 10" dia.
Pre-stretch type	Strain gauge
Pre-stretch level	250% (optional 100% to 300%)
Force control	Variable
Film threading	Octo-Thread design, W film threading pattern
Cut and seal	Controlled impulse cutter and heat sealer

Controls

Controller	Allen-Bradley PLC
Operator interface	Touch screen
Load height sensor	Photo eye
Wrap settings	Re-wrap function, overwrap and overlap adjustments
Wrap counters	Independent top and bottom
Cycle counters	Total cycle counter and resettable counter
Emergency stop	Mushroom head
Electrical disconnect	Lockable
Electrical enclosure	CSA approved

Power Requirements

Voltage	240 VAC, 20 amp, 1 phase, 60 Hz
Pneumatic	80 psi, 3 CFM (clean, dry air)

Turntable

Size	52" x 52" x 3/8" thick octagonal formed steel plate with 4" skirt
Bearing type	Ring gear

Structure

Portability	Lift truck portable front and rear
Machine weight	2,500 pounds
Construction	Heavy duty, welded
Color	Dark bronze

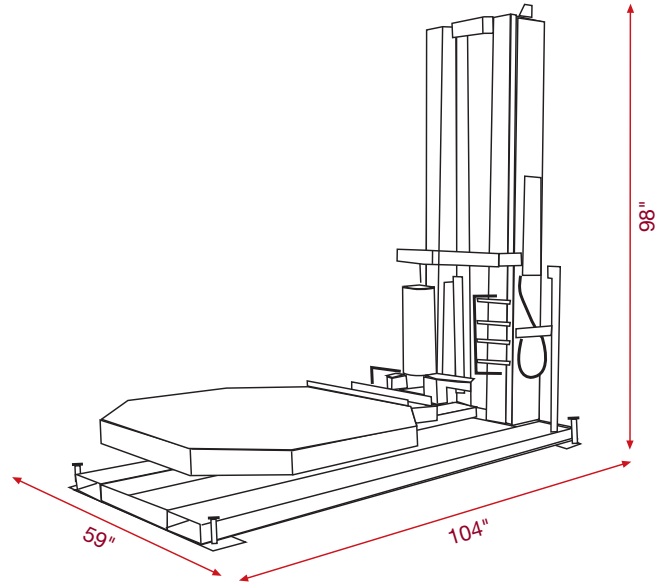

TW Muller